

# 男子団体

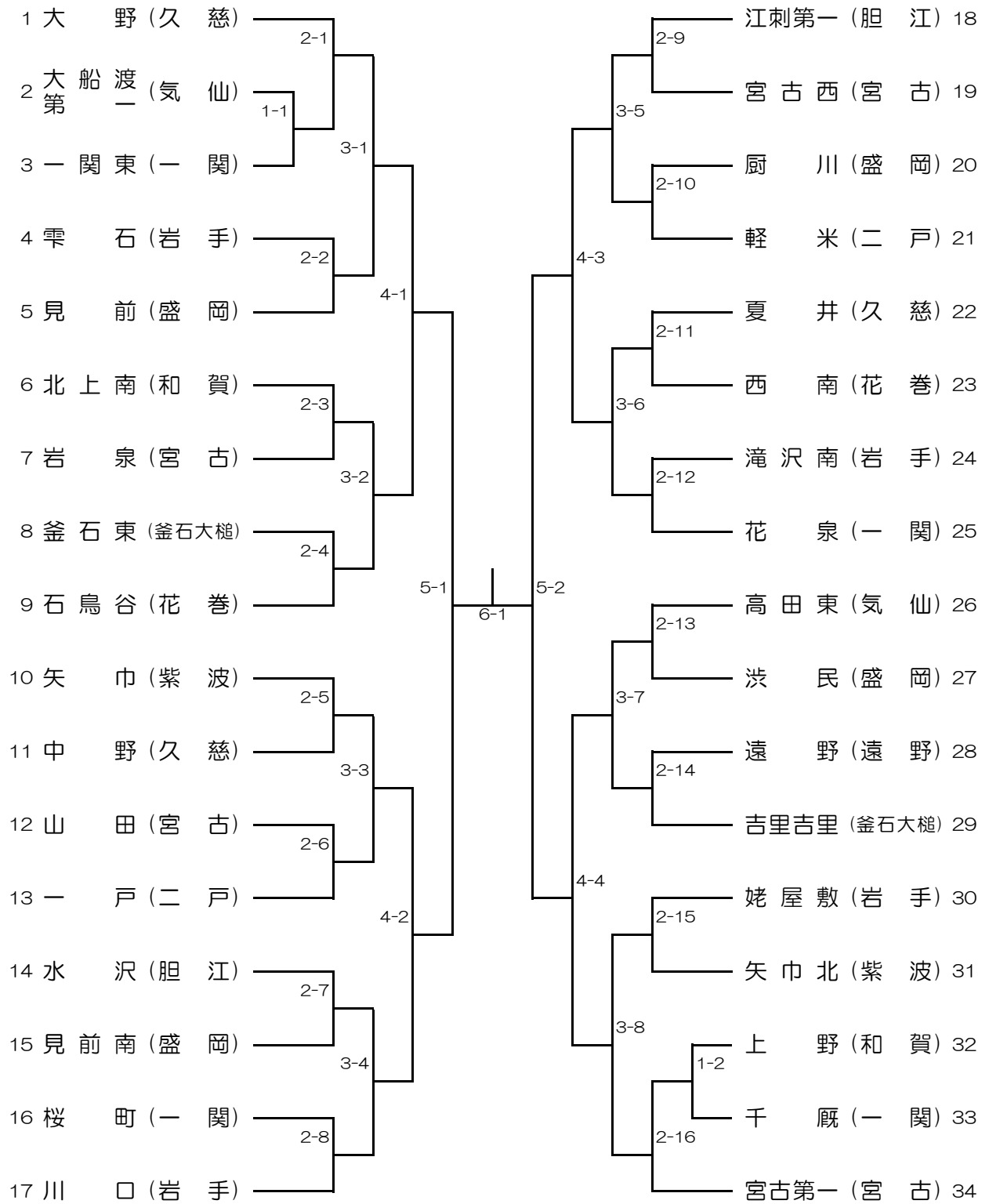

( )

ランク決定戦

( )

# 女子団体

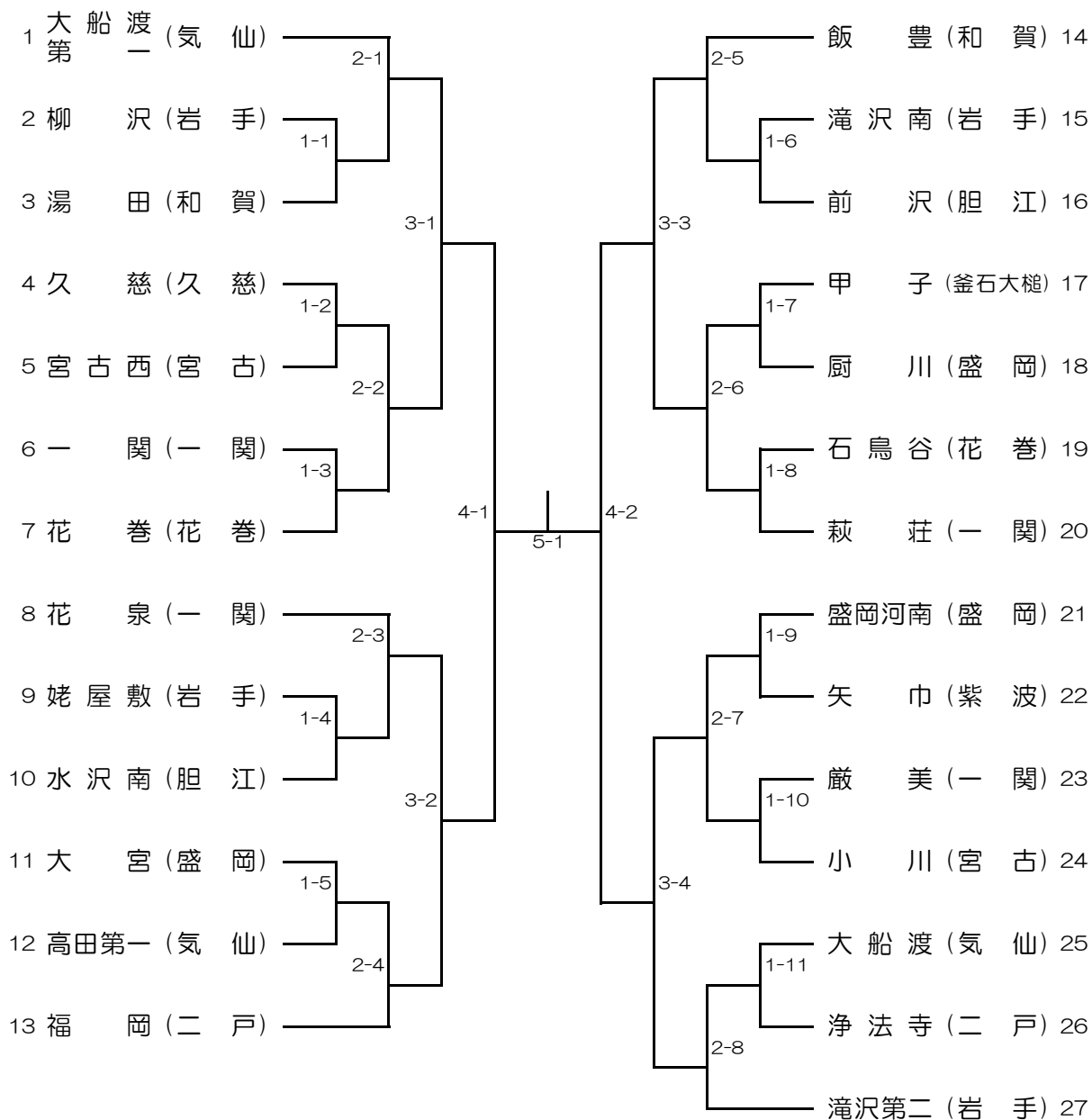

( )

ランク決定  
戦

( )

# 男子個人

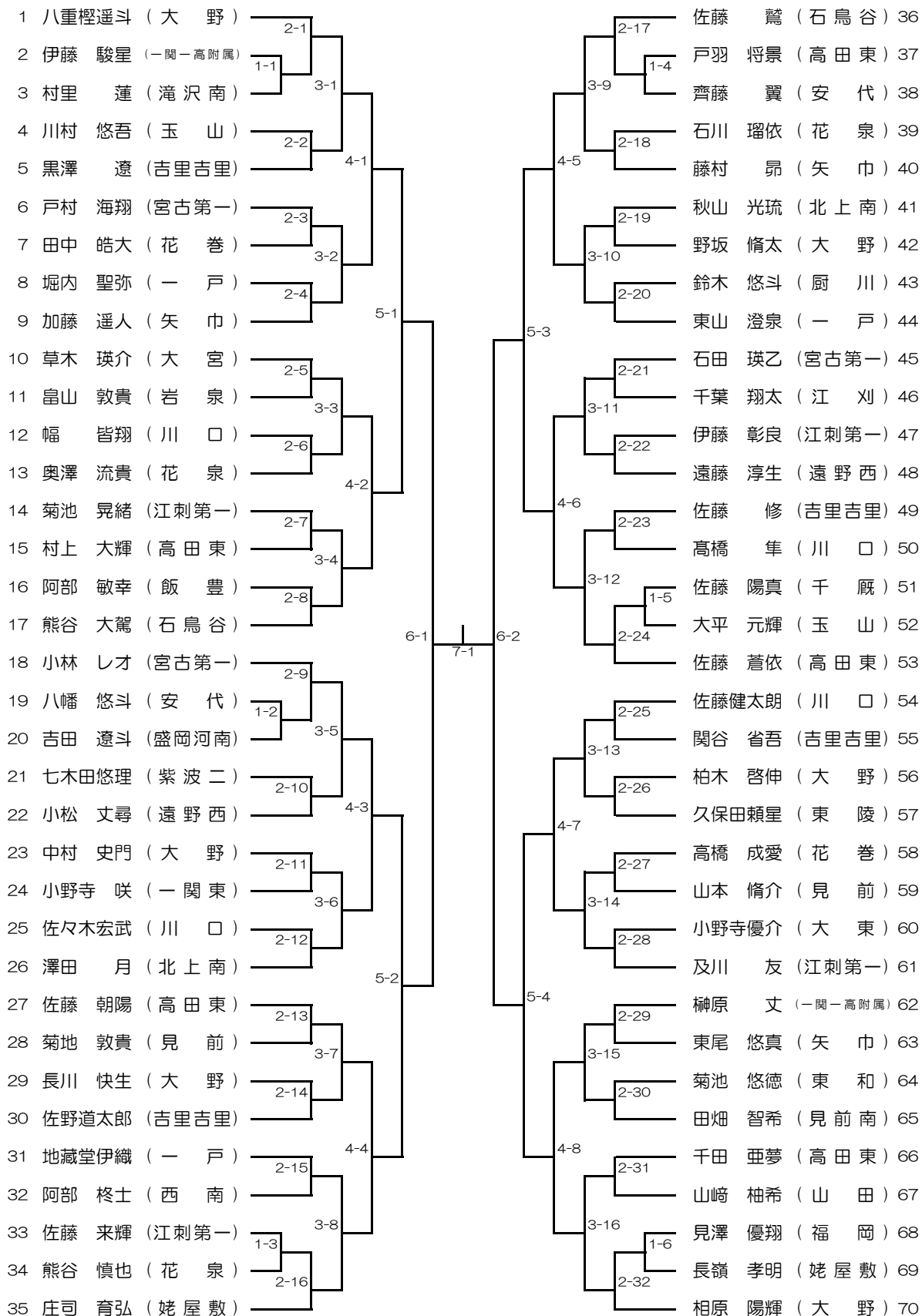

# 女子個人

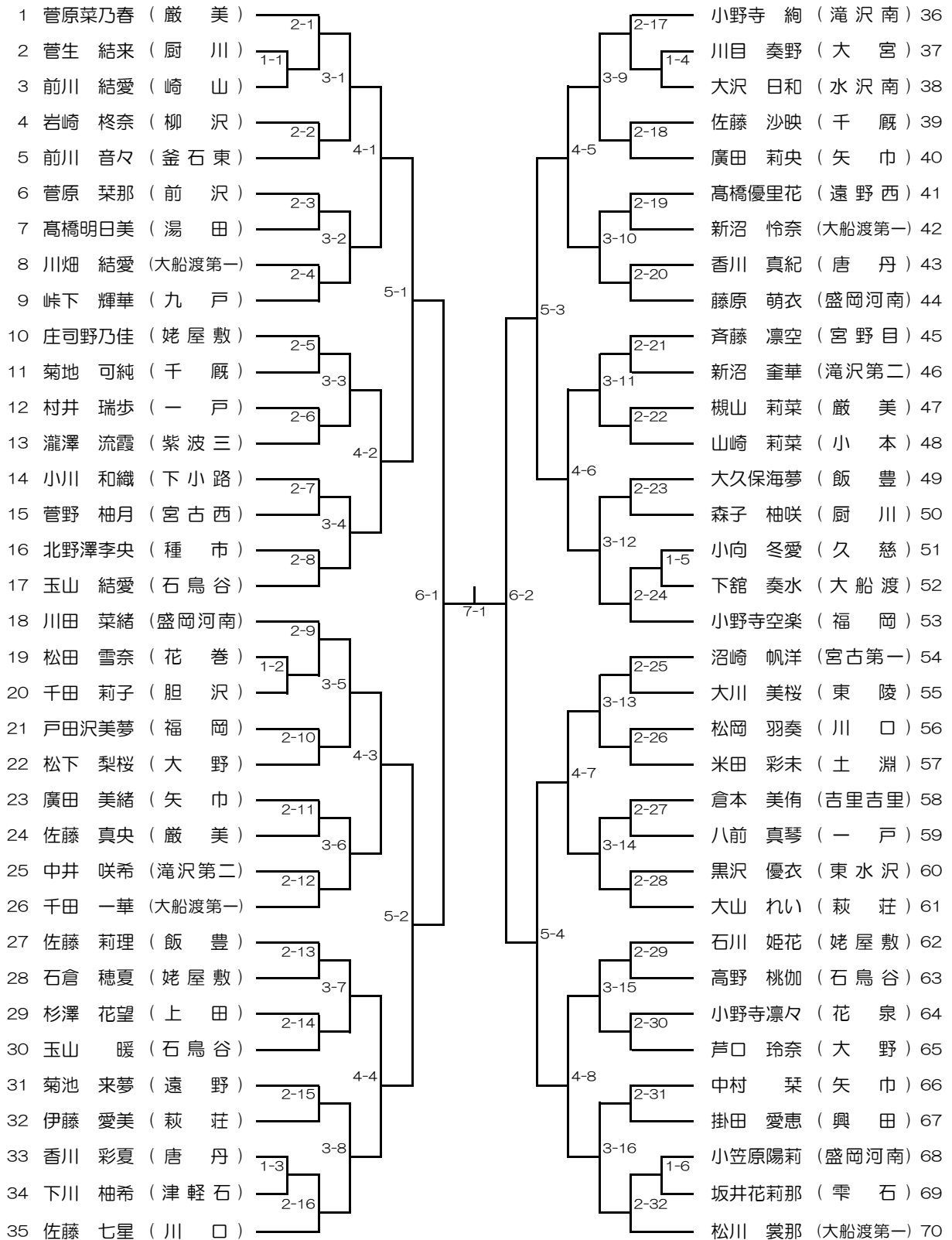

# 《16日(土) タイムテーブル》 【 T:男子団体 S:女子個人 】

試合 順序	1 10:30 ~	2 11:10 ~	3 12:30 ~	4 13:10 ~	5 13:50 ~	6 14:30 ~	7 15:10 ~	1 13:00 ~	2 13:20 ~	3 13:40 ~	4 14:00 ~	5 14:20 ~	6 14:45 ~	7 15:10 ~	8 15:35 ~	9 16:00 ~	試合 順序	
1	T	T	T	T	T	T	T										1	
2	1-1	2-1	2-15	3-1	3-5	4-1	5-1										2	
3																	3	
4	T	T		T	T	T	T										4	
5	1-2	2-8		3-2	3-6	4-2	5-2	ランク 決定戦									5	
6																	6	
7	T	T	T	T	T	T							S4-1				7	
8	2-2	2-9	2-16	3-3	3-7	4-3							S4-2	S5-1	S6-1		8	
9													S4-3	S5-2		S7-1	9	
10	T	T		T	T	T							S4-4	S5-3	S6-2		10	
11	2-3	2-10		3-4	3-8	4-4							S4-5	S5-4			11	
12													S4-6				12	
13	T	T	女子個人 参加選手 練習					S1-1	S2-1	S2-19	S2-31	S3-11					13	
14	2-4	2-11						S1-2	S2-9	S2-20	S2-32	S3-12						14
15								S1-3	S2-16	S2-21	S3-1	S3-13	S4-7					15
16	T	T						S1-4	S2-17	S2-22	S3-2	S3-14						16
17	2-5	2-12						S1-5	S2-8	S2-23	S3-3	S3-15	S4-8					17
18								S1-6	S2-10	S2-24	S3-4	S3-16						18
19	T	T						S2-2	S2-11	S2-25	S3-5							19
20	2-6	2-13						S2-3	S2-12	S2-26	S3-6							20
21								S2-4	S2-13	S2-27	S3-7							21
22	T	T						S2-5	S2-14	S2-28	S3-8							22
23	2-7	2-14						S2-6	S2-15	S2-29	S3-9							23
24								S2-7	S2-18	S2-30	S3-10							24

※記載の時間を待たず、進行を早める場合があります。

# 《17日(日) タイムテーブル》

【 T:女子団体 S:男子個人 】

試合順 コート No.	1 10:30 ~	2 11:10 ~		3 12:30 ~	4 13:10 ~	5 13:50 ~	1 13:00 ~	2 13:20 ~	3 13:40 ~	4 14:00 ~	5 14:25 ~	6 14:50 ~	7 15:15 ~	8 15:40 ~	試合順 コート No.			
1	T	T	T	T	T	T										1		
2	1-1	1-9	2-6	3-1	4-1	5-1										2		
3																3		
4	T	T	T	T	T	ランク 決定戦										4		
5	1-2	1-10	2-7	3-2	4-2											5		
6																6		
7	T	T	T	T				S2-8	S2-25	S3-5	S4-1					7		
8	1-3	1-11	2-8	3-3				S2-10	S2-26	S3-6	S4-2	S5-1	S6-1			8		
9								S2-11	S2-27	S3-7	S4-3	S5-2		S7-1		9		
10	T	T		T				S2-12	S2-28	S3-8	S4-4	S5-3	S6-2			10		
11	1-4	2-1		3-4				S2-13	S2-29	S3-9	S4-5	S5-4				11		
12								S2-14	S2-30	S3-10	S4-6					12		
13	T	T	男子個人 参加選手 練習					S1-1	S2-1	S3-1	S3-11					13		
14	1-5	2-2								S1-2	S2-9	S2-31	S3-12					14
15										S1-3	S2-16	S2-32	S3-13	S4-7				15
16	T	T								S1-4	S2-17	S3-2	S3-14					16
17	1-6	2-3								S1-5	S2-24	S3-3	S3-15	S4-8				17
18										S1-6	S2-18	S3-4	S3-16					18
19	T	T								S2-2	S2-15							19
20	1-7	2-4								S2-3	S2-19							20
21										S2-4	S2-20							21
22	T	T								S2-5	S2-21							22
23	1-8	2-5					S2-6	S2-22							23			
24							S2-7	S2-23							24			

※記載の時間を待たず、進行を早める場合があります。